



QUICK REFERENCE

for Plastic Packaging Components

Local/Worldwide Sales, Service, & Support for the Bottle Blowing Industry

Stretch Rod Cylinders

Replacement for: Sidel® Model Series1 & Series2 Machines

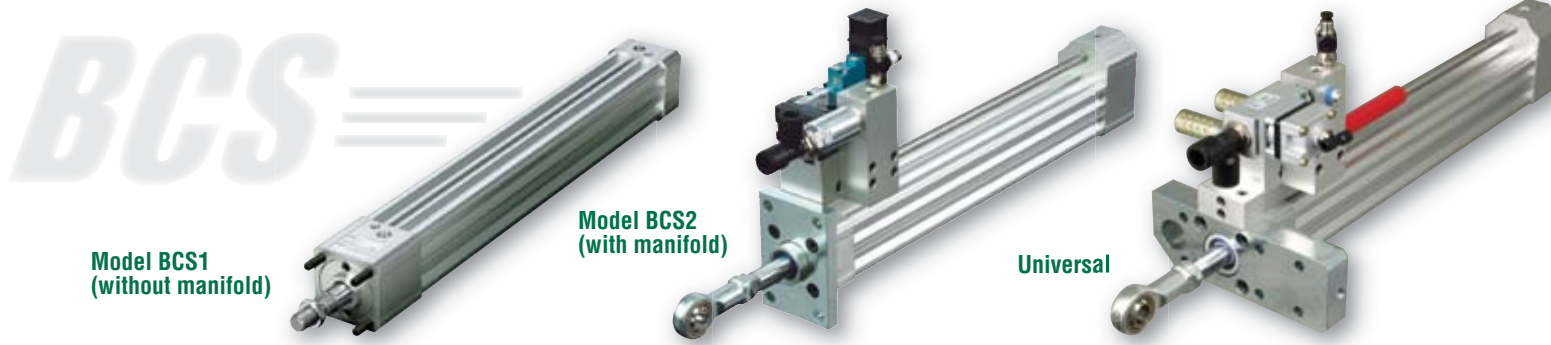

OPTIONS:

- Extended Cushions
- Extra Rod Extension
- MAC ISO 2 Series Valve with DIN Connection
- Inline Check Valve with Adaptor Block Attached to Manifold
- Pilot Operated Check Valve with Adaptor Block Attached
- Adaptor Block Attached to Manifold Only

Nozzle Cylinders

Replacement for: Sidel® Model Series2 Machines

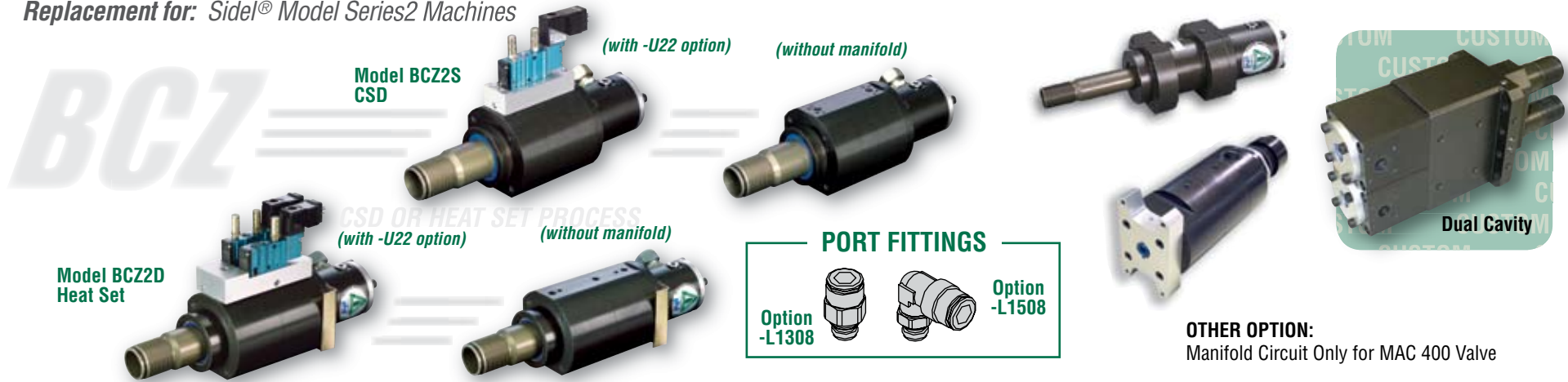

OTHER OPTION:
Manifold Circuit Only for MAC 400 Valve

Transfer Arms

Replacement for: Sidel® Series1 SB02 thru SB040 Machines

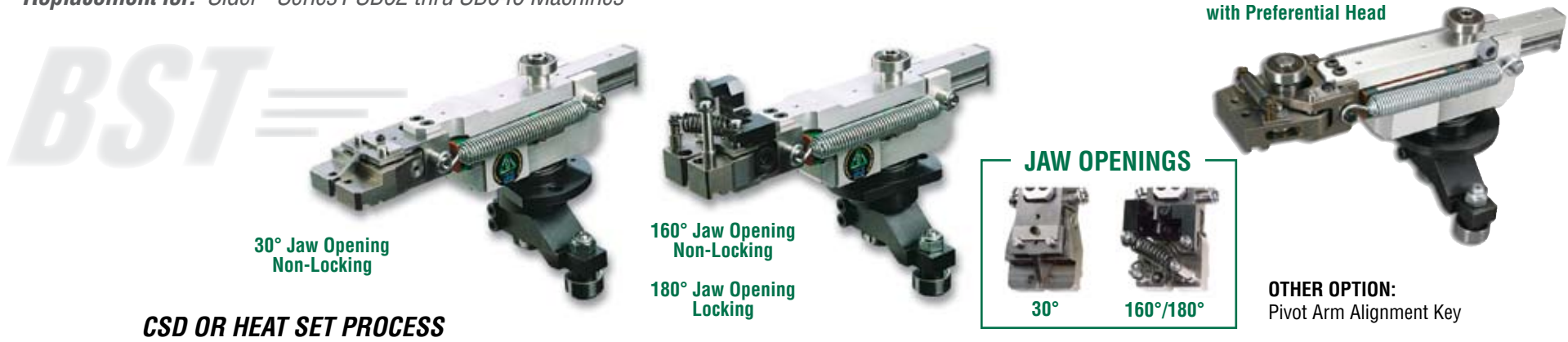

OTHER OPTION:
Pivot Arm Alignment Key

Needle Cylinders

Replacement for: Graham Wheel®, GemPak, and other continuous extrusion blow molding needle actuators. PHD offers both inner and outer mold cylinders solutions.

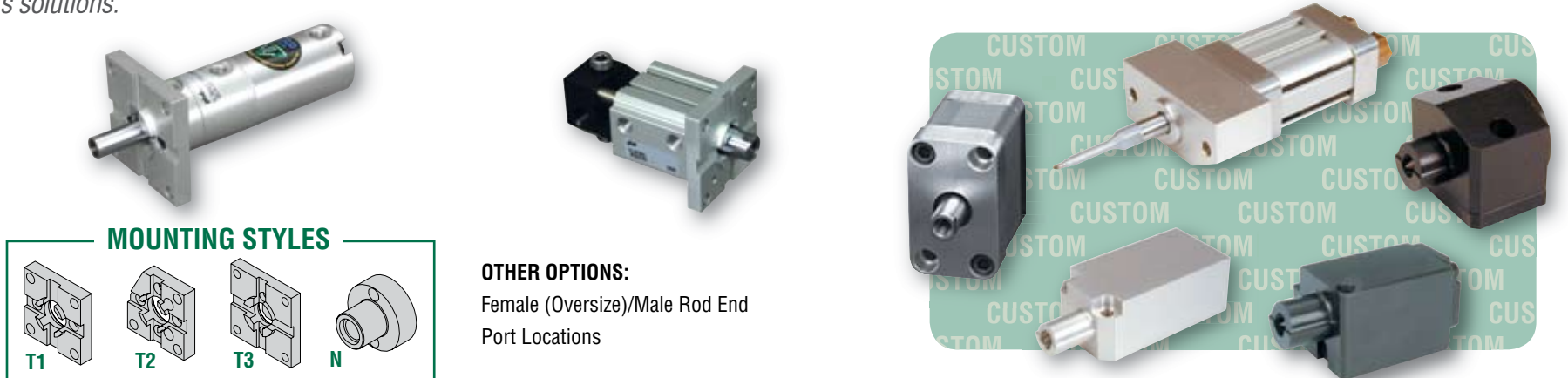

Replacement Bushings

Replacement for: Sidel® Series1 Machines



for more info on plastic packaging components:

1-800-624-8511 • www.phdinc.com

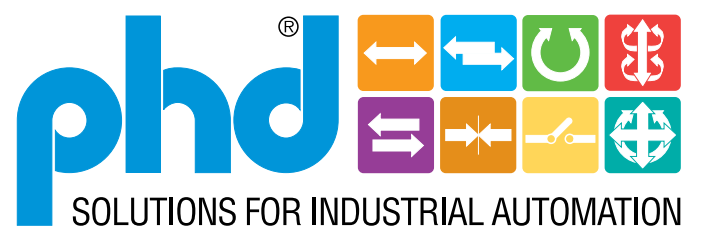

Any marks or names referenced herein are either registered trademarks or trademarks of their respective owners. No association with or endorsement of any company, organization, or product is intended or should be inferred.