



MAC/MDN Tire Industry Solution



Tire Curing Press Manifold



Manifold to control steam valves on tire curing presses

- *Reduces Installation Cost*
- *Reduces Operational Costs*
- *Ease of Troubleshooting*



Development

The design and development strategy of the new curing bar manifold was to help reduce installation and operating costs of curing presses. Air valves are not a high percentage of the total cost of an actual press, it has been found that traditional valving had several inefficiencies which increase the total cost of ownership.

Cost Savings

The curing bar manifold has been developed with overall cost reduction as the driving factor.

Installation cost savings:

- **Reduction in Wiring:** Using a standard multi-conductor connector in the base of the unit allows for reduction in wiring cost. The single connection reduces traditional din style connectors and their corresponding distribution blocks.
- **Smaller Package:** Taking up less space than the traditional valving, allows for the unit to be mounted near the steam valves which they control. Locating the manifold close to the steam valves allows for a reduction in material and labor. The smaller package size allows press builders to fit a larger press in a smaller footprint.
- **Reduction in Plumbing:** The curing bar manifold reduces the need to run low pressure compressed air on the press. It does this by integrating dual regulators on the manifold. These regulators allow for standard 100 psi air to be supplied to the pilot valves, maintaining strong shifting forces, while allowing the reduced compressed air pressure in the main body to operate the steam valves.
- **Integrated Proportional Pressure Control:** The curing bar manifold includes the new MAC I/P valve. By locating this unit on the manifold it reduces plumbing and wiring. The valve has a standard 12mm connector and manifold mounting to ease field replacements.
- **Reduction in Installation Time:** The curing bar manifold integrates the Legris push to connect fittings. These nickel plated fittings have high temperature seals and allow for connection to steel, copper or plastic tubing.

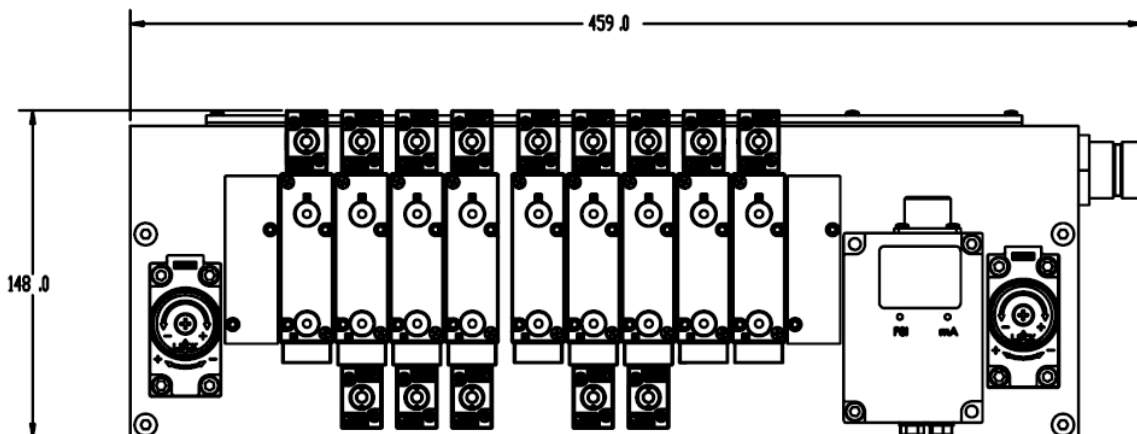

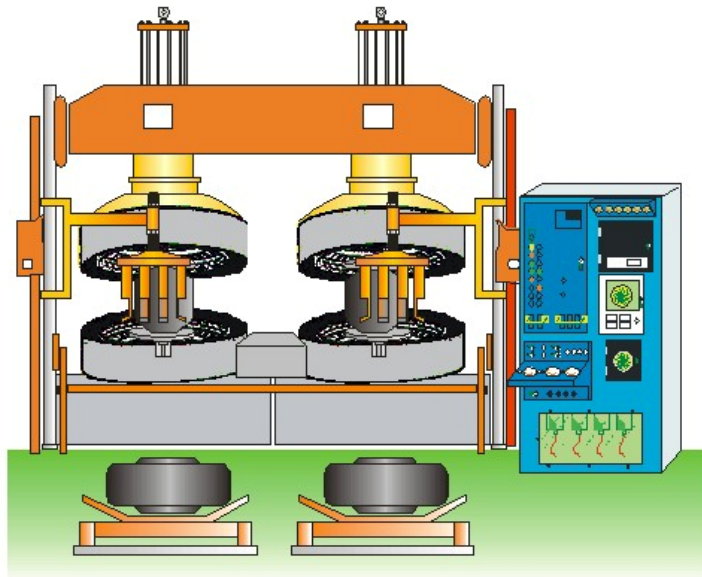

Cost Savings

Operational cost savings:

- Increased Reliability / Reduced Downtime:** By integrating the curing modifications to the valves (high temperature seals, high temperature grease and long energization coils) along with the pre-burn in testing, we ensure longer lasting more reliable valves. The 92 series valves with the MACSolenoid, short stroke high shifting force coil, and 4-way pilot design offers the longest valve life in the industry.

Diagnostics

- Ease of Trouble Shooting:** The manifold integrates individual exhausts. This allows for simplistic identification of leaking steam valves.

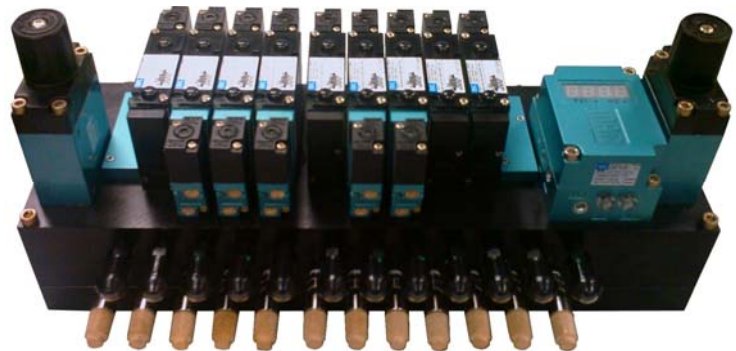

- Diagnostic Module:** The manifold has an optional breakout box that is used to diagnose system problems. This box comes with individual overrides for each of the valves, as well as, indicator lights to verify power to the valve has been made. It is easily connected to the standard multi-pin connector.
- LED's:** Each valve houses an LED to verify if the valve has received an electronic signal from the PLC.
- Pressure Indicators:** The manifold integrates air pressure indicators for each pneumatic output, to allow the user to verify the valve is sending a pneumatic signal to the steam valve.
- Proportional Pressure Control:** The Mac PPC has integrated a digital display which show the input current (4-20 Ma) and the output pressure (0-30 psi). This allow the user to verify the shaping valve is receiving the correct pneumatic signal.



19 Pin Molded



Pressure Indicators



92 Series Valves with Curing Modification

92 Series Valve Features

The 92 series pneumatic controls valve has several features that ensure repeatability and reliability in the tire curing environment. The basis of the technology is to provide strong shifting forces on both the pilot valve and the main spool to ensure reliable control of air in the worst of environments.

Solenoid Pilot Operated Valve: The basic technology of using a smaller pilot valve to control a larger slave valve enables higher flows without sacrificing shifting forces. This higher flow allows the valve to operate either the diaphragm or piston type steam valves.

MacSolenoid: The MacSolenoid integrates several features that are unique that contribute to its reliability:

- **Short Stroke solenoid produces high energization shifting force.**
- **High force return spring due to high force solenoid, maximizes both energization and de-energization shifting forces.**
- **Built-in wear compensation - valve stroke is shorter than solenoid stroke.**
- **Solenoid closes regardless of position of valve, virtually eliminating coil burnout on AC service.**

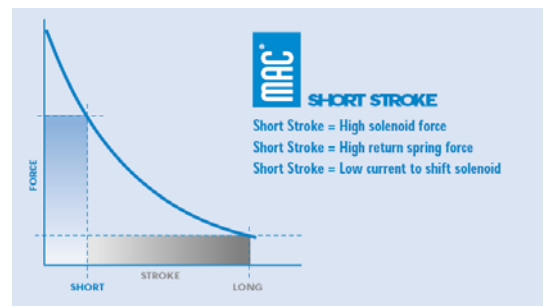

Short stroke = High force = Valves that don't stick

Mac's 4-Way Pilot System allows for higher shifting forces in the main spool by eliminating the need for a return spring. Traditional pilot valves (3-way) provide a signal to one side of the spool and rely on a mechanical spring, pneumatic spring or both to return the spool. The 4 way pilot system uses a controllable signal on each side of the main spool. This allows the valve to overcome more compressed air contamination that is typically in the curing environment.

Balanced Poppet Design allows for consistent shifting forces at different pressures. This eliminates the need to have multiple pilot valves for different pressures as seen with the Skinner and Asco type designs.

Maximized Exhaust Flow Paths in the pilot valve prevent contamination build up as seen in the Asco and Skinner type valves.

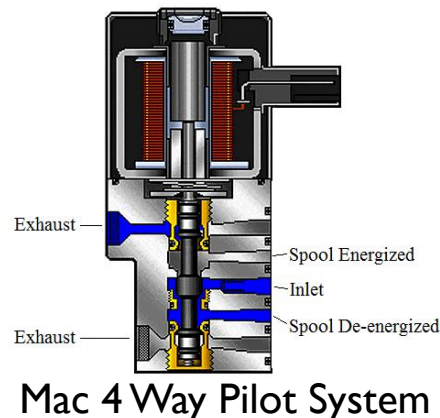
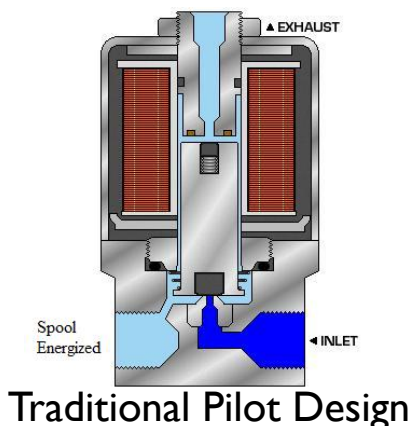



92 Series Valves with Curing Modification

92 Series Valve Features

Bonded Viton Rubber Spool allows for contact with the bore generating a wiping action. High temperature compounds which are resistant to chemicals are used in place of the standard Buna compound. The Bore is machined, roller burnished and polished for a glasslike finish this creates minimum friction, minimum wear and longer life.

Balanced Spool Design allows for consistent shifting forces that are unaffected by pressure. This allows the control of low pressure diaphragm, or higher pressure piston type steam valves.

High Temperature Grease creates a more reliable lubricated valve. Typical valve lubrication can break down in high temperature. The high temperature lubrication is applied to the spool and pilot, therefore does not external lubrication.

High Flow design allows for the same valve to be used throughout the machine. The ability to use one valve for the internal and external schematic reduces inventory needs and increases the commonality of parts.

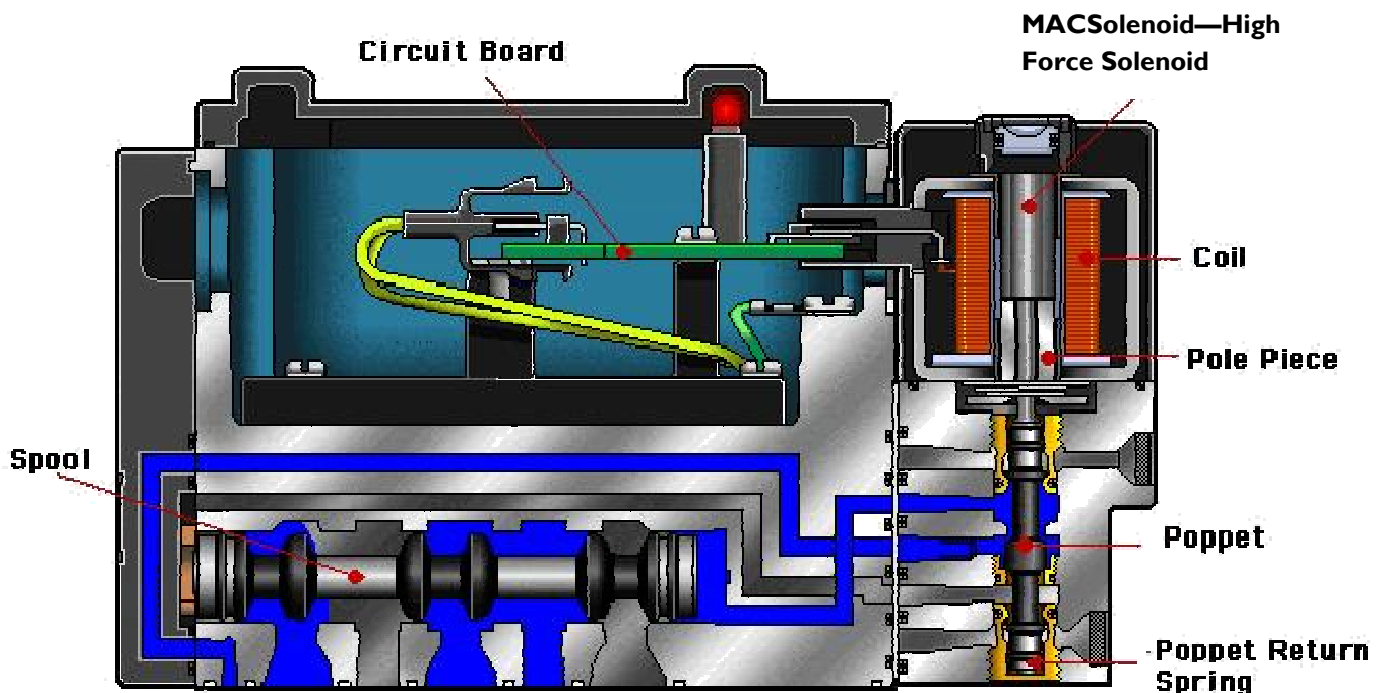



Manifold Features

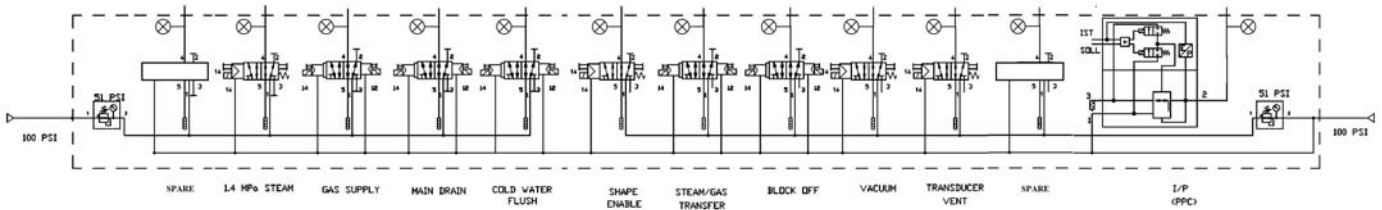
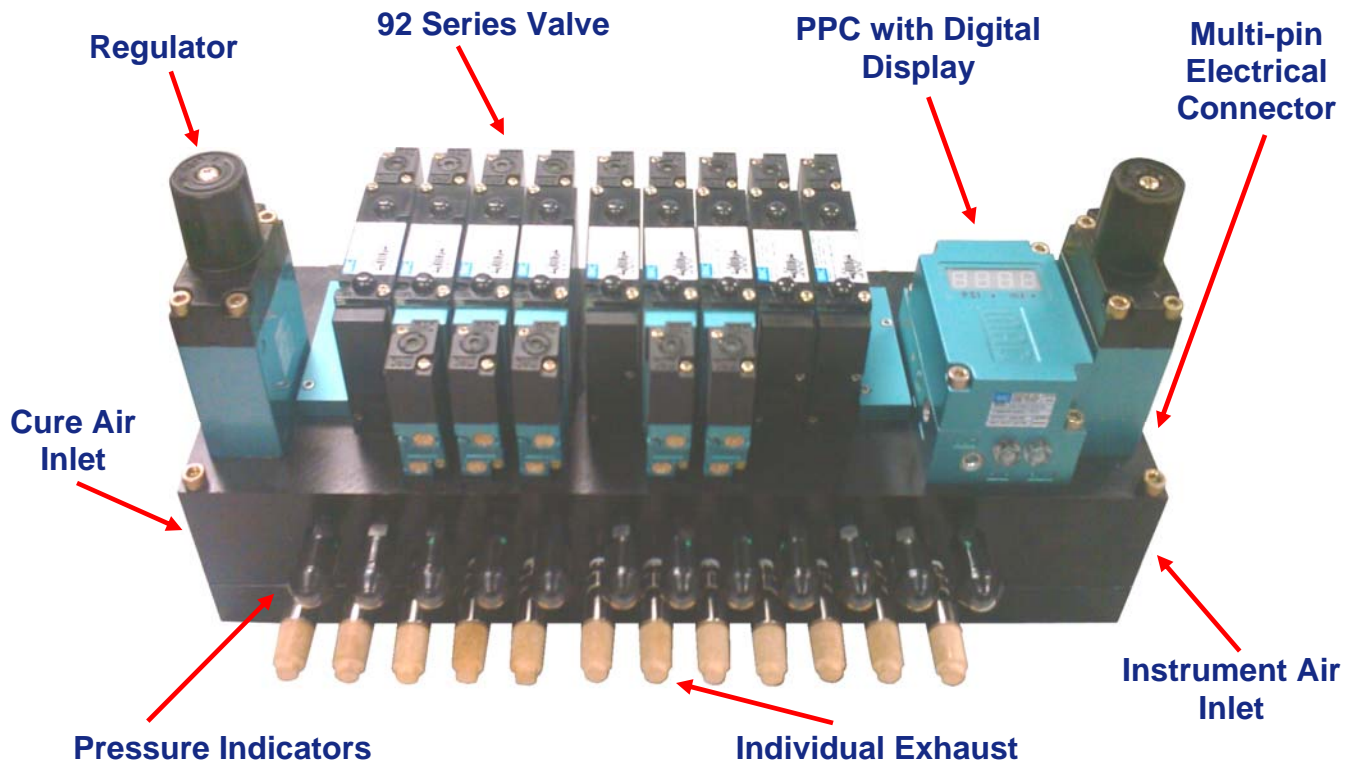



Bill of Material FS-10280

Qty	Part Number	Description
1	EBA-92052	Curing Bar Assembly
4	92B-AAF-000-DM-DDAP-IDM = 7677	Single Solenoid 24 VDC, 5 Port 2 Position, with Curing Mod
5	92B-BAF-000-DM-DDAP-IDM = 7677	Double Solenoid 24 VDC, 5 Port 2Position with Curing Mod
2	M92002	Blank Station Cover
2	PR92A-J0AB = 446R	Regulator with Gauge 0-100 PSI
1	PPC5C-AGA-CGAA-CAA-A0 = 7672	PPC with Digital Read Out, 4– 20 Ma, 0-30 PSI 1.5% Acc. Manifold Mount.
1	CBM092B-10041-C013	Special Curing Bar Manifold
1	FS-09490A	Curing Bar Manifold Kit
	1	19 Pin Mini C Cord 15 Meters
	1	3 Pin Mini C Cord 15 Meter
	12	Legris Muffler 6 mm Barb
	12	Legris Fitting for Muffler 1/8" BSPP to 6 mm Tube
	2	Legris Fitting for Inlets 3/8" BSPP to 10 mm Tube
	15	Legris Fitting for Outlet 1/4" BSPP to 8 mm Tube
	12	Pressure Indicators
	1	80/20 Mounting Hardware Kit



The MAC Distributors Network is a customer assistance tool providing global sales and service for MAC Valves' customers worldwide.

With partners in 45 countries, 200 service centers and warehouses holding 50 million dollars in inventory world wide, MDN is equipped to aid you with initial designs and after sales assistance.

MDN is a unified sales force of approximately 3500 qualified sales personnel, including approximately 1000 pneumatic applications specialists trained to assist you with any application or requirement worldwide. They can provide quick access via local inventory by authorized MAC Valves Distributors, an independent/interdependent force for pneumatic valves applications.



MAC Distributor Network